



**Mechanical Design and Fabrication of the U.S.
Solid Breeder Blanket for ITER**

I.N. Sviatoslavsky, J.P. Blanchard, Y. Gohar, S. Majumdar

October 1990

UWFDM-836

Presented at the 9th Topical Meeting on the Technology of Fusion Energy, 7-11 October 1990, Oak Brook IL.

FUSION TECHNOLOGY INSTITUTE

UNIVERSITY OF WISCONSIN

MADISON WISCONSIN

DISCLAIMER

This report was prepared as an account of work sponsored by an agency of the United States Government. Neither the United States Government, nor any agency thereof, nor any of their employees, makes any warranty, express or implied, or assumes any legal liability or responsibility for the accuracy, completeness, or usefulness of any information, apparatus, product, or process disclosed, or represents that its use would not infringe privately owned rights. Reference herein to any specific commercial product, process, or service by trade name, trademark, manufacturer, or otherwise, does not necessarily constitute or imply its endorsement, recommendation, or favoring by the United States Government or any agency thereof. The views and opinions of authors expressed herein do not necessarily state or reflect those of the United States Government or any agency thereof.

**Mechanical Design and Fabrication of the U.S.
Solid Breeder Blanket for ITER**

I.N. Sviatoslavsky, J.P. Blanchard, Y. Gohar, S. Majumdar

Fusion Technology Institute
University of Wisconsin
1500 Engineering Drive
Madison, WI 53706

<http://fti.neep.wisc.edu>

October 1990

UWFDM-836

Presented at the 9th Topical Meeting on the Technology of Fusion Energy, 7–11 October 1990, Oak Brook IL.

MECHANICAL DESIGN AND FABRICATION OF THE
U.S. SOLID BREEDER BLANKET FOR ITER

I.N. Sviatoslavsky, J.P. Blanchard
Fusion Technology Institute
University of Wisconsin-Madison
1500 Johnson Drive
Madison, WI 53706
(608) 263-6974

Y. Gohar, S. Majumdar
Fusion Energy Program
Argonne National Laboratory
9700 South Cass Avenue
Argonne, IL 60659
(708) 972-4816

ABSTRACT

The solid breeder blanket has been chosen as the first option for ITER, with three of the four participating international groups submitting designs utilizing solid breeding materials. This paper describes the design submitted by the U.S. group. The ITER chamber will have both inboard and outboard blankets. The outboard side is divided into 48 modules, three per TF sector, where one central module fits between TF coils and two side modules fit partially within the coils. The central module is divided into an upper and lower segment leaving space at the midplane for penetrations. These penetrations include spaces for test modules, neutral beams and RF heating units. The two side modules extend the full height of the reactor. The inboard side is divided into 32 modules with each module separated into three electrically insulated front zones. A slab configuration is used within the blanket, where Be zones are interleaved with thin LiO₂ solid breeder zones and water coolant panels. In the outboard blanket the first wall and coolant panels have toroidal channels while the inboard blanket has poloidal channels. The first wall has to be designed to be capable of withstanding the pressure generated by plasma disruptions. An independent coolant loop is used for the first wall while the blanket and shield are integrated into another loop.

GENERAL DESCRIPTION OF OUTBOARD BLANKET

The outboard (OB) blanket is divided into 48 segments of equal toroidal extent, three segments for each toroidal field (TF) coil sector. The three segments consist of a central segment and two side segments. The side segments extend the full height of the reactor and will henceforth be called side modules. The central segment is located between TF coils and is divided into an upper and lower module. A penetration is situated at midplane between the upper and lower central modules. Each side module lies partially in the shadow of a TF coil. Thus, the back of each side module has part of it rounded to fit the contour of the vacuum chamber within the TF coil and part of it straight from top to bottom to fit the vacuum chamber between the TF coils. Central modules have straight backs and come out of the reactor vertically without

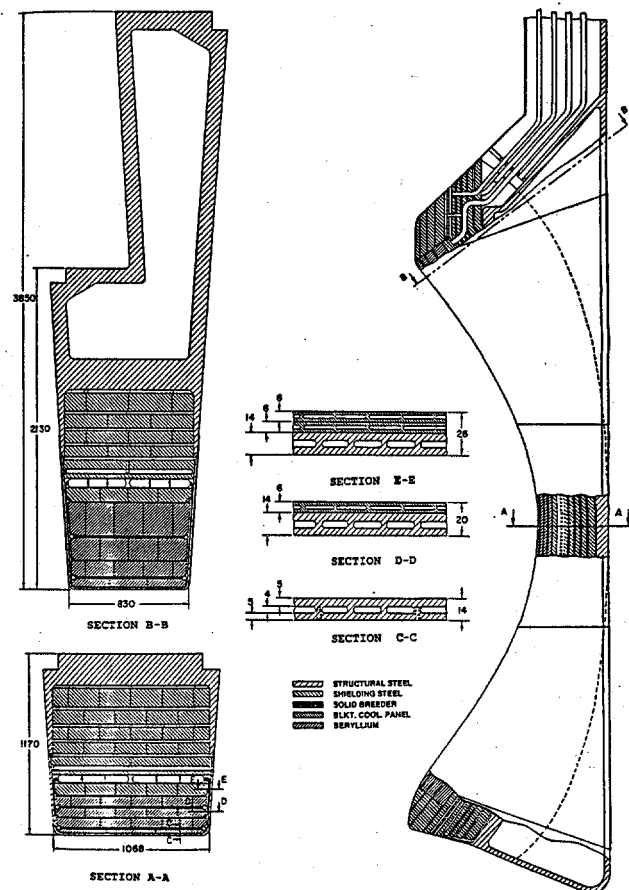

Figure 1. Outboard side module.

circumferential displacement. Side modules require a circumferential translation before they can be extracted through the upper maintenance port. Side modules and upper central modules have service connections at the top, while the lower central module has service connections at the bottom.

The OB solid breeder blanket module design is of slab configuration consisting of Be plates interleaved with solid breeder zones and coolant panels, all contained within a stainless steel box. Figure 1 shows a view of a side module with cross sections at midplane and at the upper extremity. From Figure 1 it will be noted that the breeding zone thickness increases from midplane to the upper extremity. This is done as part of the solid breeder temperature control system. As the neutron wall loading decreases at the extremities, the Be zones are increased in thickness in order to maintain the solid breeder within the desired temperature window. There are two solid breeder zones and two blanket coolant panels extending the full height of the module. The present design can accommodate three solid breeder zones and three coolant panels with minimal impact on the complexity. This can result in a substantial increase in the tritium breeding ratio. It should be noted that the solid breeder zones and coolant panels are of constant thickness regardless of their poloidal location. There are four Be zones. The first is immediately behind the first wall, the second immediately behind the 1st solid breeder zone, the third behind the first coolant panel and the fourth, behind the 2nd solid breeder zone. The last layer in the front breeding part consists of steel plates and is located immediately behind the 2nd coolant panel. It is followed by the oblong manifolds which supply the blanket coolant panels.

The toroidal width of the OB modules also varies from top to midplane, with the nominal dimensions shown in Figure 1. The Be plates are segmented in the toroidal direction to prevent excessive distortion due to thermal stress. Since control of the solid breeder temperature depends on the Be thickness and the gap resistances, it is imperative to insure that the Be and solid breeder surface conform to the coolant panel surfaces. The Be plates zone is purged with He gas to prevent accumulation of T_2 in this area. This is accomplished by providing spaces at the interfaces between the Be plates and the side walls as shown in Figure 1. These spaces act like manifolds for distributing He gas poloidally. This gas then flows toroidally across the Be plates and comes out on the other side of the module. Precautions must be taken to prevent short circuits of the gas at the top and bottom of the module.

The solid breeder consists of Li_2O panels 0.8 cm thick clad in 0.1 cm thick SS sheets. The panels are continuous from top to bottom and have built-in manifolds on the sides running in the poloidal direction. Purge gas flows poloidally through the manifold, then toroidally across the panel through machined grooves and finally back out through the return manifold. This purge gas carries with it the T_2 which is bred in the solid breeder.

The first wall (FW) consists of a 1.4 cm thick plate with built-in rectangular channels, 0.4 cm \times 2 cm separated by 0.3 cm walls. It is assembled from two extruded SS plates, each with one half channel embossed on one side. The two sheets are assembled with the

channel wall separations making contact and continuously spot welded, thus forming the plate with the built-in channels. Section C-C, D-D and E-E of Figure 1 show a cross section of the first wall. The plate orientation is such that the channels run along one side wall, then toroidally through the FW and back along the other side wall. This insures good cooling of the side walls and the FW. The FW also has blind holes drilled and tapped for attachment of graphite tiles during the technology phase of operations. Section DD of Figure 1 shows the FW followed by a single blanket coolant panel and section EE, by two blanket coolant panels. These coolant panels are made the same as the FW but are only 0.6 cm overall thickness and have 0.2 cm \times 2 cm coolant channels separated by 0.2 cm thick walls. The panels are brazed to oblong supply and return manifolds which extend poloidally the full length of the module and are reinforced by through studs to prevent transfer of pressure to the blanket components.

The next two steel plates play an important role in the blanket design. These plates are 3.2 cm and 6 cm thick, respectively, and are separated by a 3 cm gap, are continuous top to bottom and are welded to the module side wall all around. They serve three main functions:

- 1 - The first plate completely seals the front breeding zone from the FW coolant manifolds. No water can be allowed to permeate the breeding zone materials which operate at very high temperatures.
- 2 - The 3 cm space between the two plates defines the supply and return manifolds for the FW coolant.
- 3 - The two plates act as structural elements tying the two sidewalls of the blanket module together and effectively create a box for the breeding zone materials.

The poloidal extent of the OB breeding blanket is ± 4.1 m. The actual first wall extends somewhat further. These zones which extend beyond the breeding blanket consist of steel plates and cooling panels instead of Be and solid breeder plates. The sidewall and first wall configuration is, however, the same.

Figure 2 shows several views of an upper central module. On the right is a side view with the sidewall removed to show the internal details of the blanket. Section A-A is a cross section near the lower end of the blanket (nearest to the penetration). Section C-C, D-D and E-E are of the FW and side walls. Note that the copper stabilizer sheet is on the inside of the blanket on the FW and on the outside on the sidewalls.

INBOARD BLANKET

There are four important differences between the inboard (IB) and the outboard (OB) blanket, which are:

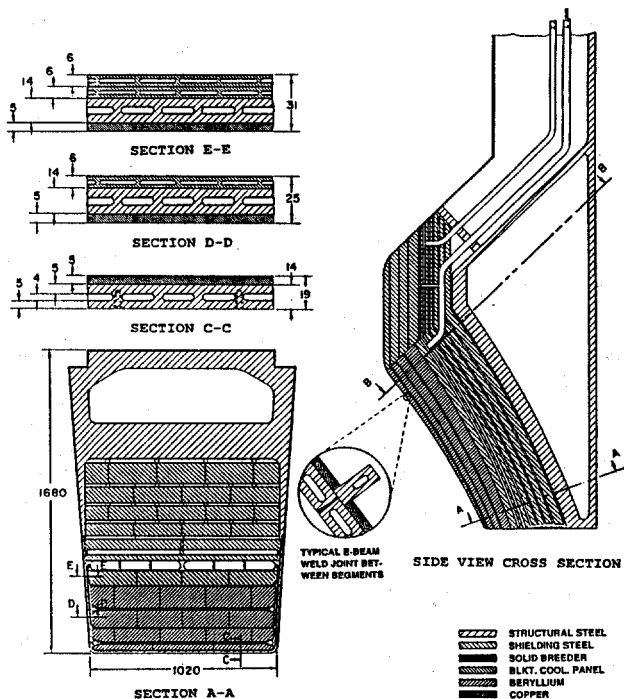

Figure 2. Outboard central upper module.

- 1 - IB blanket has poloidal coolant flow
- 2 - IB blanket has only one solid breeder zone
- 3 - IB module is subdivided into three electrically insulated parts
- 4 - Fabrication and assembly of the IB blanket is radically different from the OB blanket.

The IB blanket is divided into 32 toroidally equal modules, or two modules per TF coil and extends ± 3.5 m from midplane. The centerlines of the modules never coincide with the centerlines of the TF coils. Thus the two modules fit between two TF coil centerlines.

Figure 3 is a midplane cross section of the IB module. The FW, side walls and blanket coolant panels are fabricated the same as in the OB blanket; however, the coolant channels run in the poloidal direction. As in the OB blanket, the radial build is smaller at midplane than at the extremities. Water and purge gas connections are all at the top.

To reduce disruption effects, each module is subdivided into three parts, electrically insulated from each other. The insulated zone extends 27 cm at midplane and 53 cm at the extremities. The three parts of the module are then E-beam welded together in the back and then bolted to a common shield backing. The solid breeder and the Be zone are purged with He gas.

The FW is 1.5 cm thick and has 0.5 cm \times 3.48 cm coolant channels spaced 2 mm apart. These spaces are

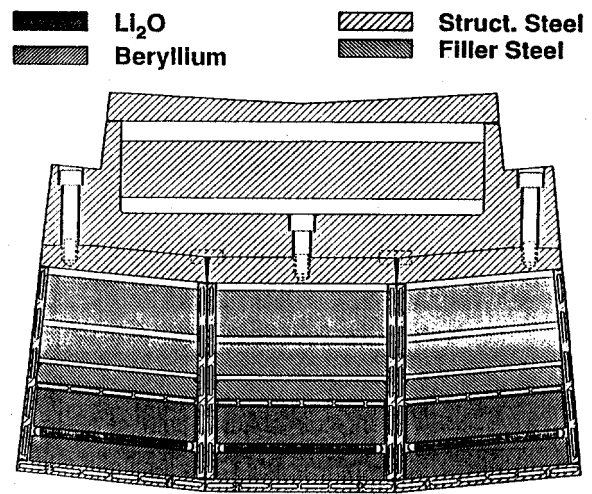

Figure 3. Inboard module midplane cross section.

increased in some places to allow room for fasteners needed to attach graphite tiles during the technology phase of operations. Side walls are 1.0 cm thick and have 0.3 cm \times 3.8 cm channels spaced every 1.2 cm.

FIRST WALL SUPPORT

The FW has two loads which it must deal with, a vacuum load from the plasma chamber and disruption loads. The analysis related to the maximum toroidal span that can be tolerated is not given in this paper. In this section we will address the impact of such a requirement on the mechanical design.

Figure 4 gives the average pressure at 5 ms following a disruption. It will be noted that the maximum pressure of 0.9 MPa occurs at midplane. It is obvious that the most severe loading condition is at midplane and thus affects only the side modules. The allowable toroidal span between stiffeners, assuming an added vacuum load of 0.1 MPa, making the average uniform midplane load equal to 1.0 MPa, is equal to 22 cm.

Toroidal stiffeners (see Figure 2) which were originally contemplated for the FW must now be attached to back shield structure in order to provide the required support against disruption loads. The attachment can be in the form of rods which are welded to the stiffeners and then to the front plate of the FW cooling manifold. Figure 5 shows how this can be accomplished. Sealed penetrations have to be provided through the breeder panels, the cooling panels and through the blanket coolant manifolds. This is a minor complication in the design and has minimal impact on the total material fraction in the blanket and will not reduce the breeding ratio appreciably. At midplane the stiffeners must be 22 cm apart and the

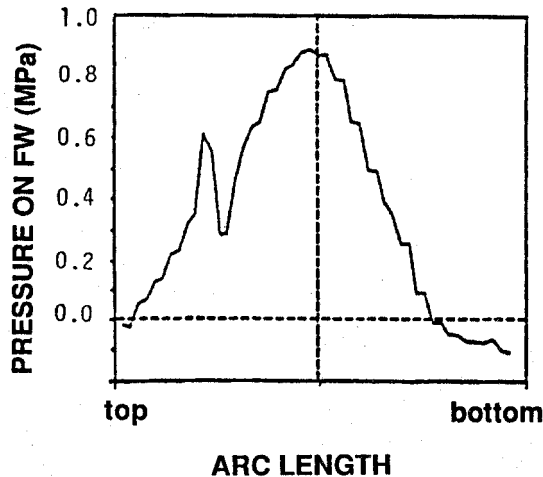

Figure 4. Average pressure on OB FW at $t = 5$ ms.

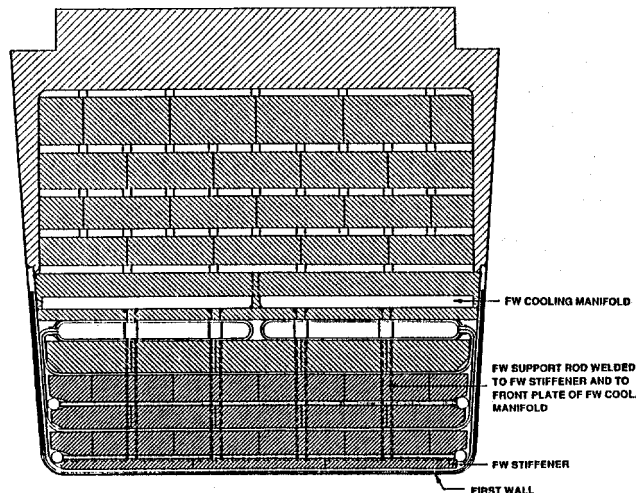

Figure 5. First wall supports.

rods are spaced to divide the toroidal span into 5 equal distances, or ~ 21.4 cm apart. The spacing of the stiffeners is increased in either direction from midplane and the spacing between the rods will be increased proportionately. Preliminary analysis indicates that these rods can be cooled by conduction if they can be adequately grounded to the cooling panels as they go through them. Another interesting idea is to make these rods as double ended heat pipes with sinks at either end.

COPPER STABILIZER COIL INTEGRATION

The side view in Figure 1 shows the outline of the passive stabilizer coils. They are located on the upper and lower third of the side module, starting at $z = \pm 1.8$ m extending to ± 4.3 m at the first wall and to ± 5.0 m at the

rear. These coils cover the entire poloidal span of the center modules. The coils are in the form of 0.5 cm thick copper plates which subtend the blanket module on all four sides. Section C-C of Figure 2 shows the copper plates on the inside of the first wall and Section D-D and E-E on the outside of the side walls. The plates are brazed to the blanket wall structure and thus do not require separate cooling.

PENETRATION ACCOMMODATION

Each space between TF coils at the midplane has penetrations which are used for various functions such as test module placement, RF heating modules and neutral beam tubes. Test module penetrations which are nominally 1 m toroidal extent and ± 1.7 m in poloidal extent are easy to accommodate. The central part is split into an upper and a lower module, providing the space needed for the penetration at midplane. The upper module has service connections at the top and the lower module at the bottom.

The more difficult penetration to accommodate is the neutral beam tube, which comes in tangent to the circumferential centerline of the plasma and thus sweeps across two side modules and one central module. The neutral beam tube is 80 cm wide and extends ± 1.7 m in the poloidal direction from midplane. The side module and central module on either side of the NB penetration can be modified as shown in Figure 6a and 6b. Figure 6a shows the front right corner of a side module and Figure 6b the rear left corner of a central module modified to allow for the penetration, where arrows show the water flow direction in the FW. Figure 7 shows the NB penetration going through a side module at a slant. Section A-A shows how the coolants and purge gases are shunted from the lower to the upper segment, and the arrows indicate FW water flow direction.

BLANKET/SHIELD INTEGRATION

In the solid breeder design, the blanket and shield are integrated both structurally and thermal hydraulically. This means that both blanket and shield are assembled outside the reactor into a single unit which is called a module. When loaded into the reactor as a module, a single set of cooling and purge gas connections have to be made to provide the services for that module.

Figures 1 and 2 show this integration for the OB side and center modules respectively. It can be seen that the breeding zone which occupies the front part of the blanket shares the same structural box as the shield which makes up the rear part. There is one distinction which must be kept in mind: the breeding part is sealed off from the shield part by the front plate of the FW cooling manifold. No water can be allowed to permeate into the breeding part except in the cooling panels, where it is isolated, and will never come in contact with the hot Be plates or the solid breeder cladding. In the shield part, the water flows through gaps between the steel plates and is not contained

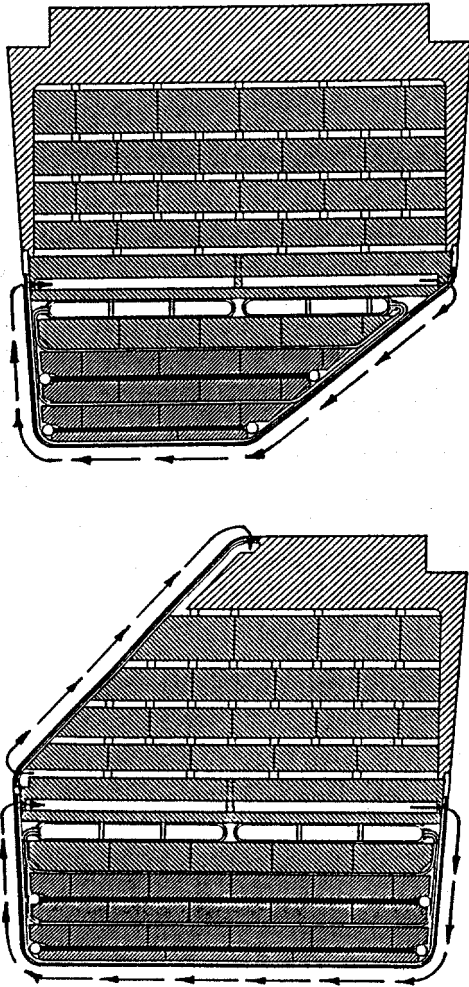

Figure 6a and 6b. Blanket modification for NB.

within sealed channels. The nuclear and thermal hydraulics details for this design are given in companion papers in these proceedings.

The IB side also has the blanket and shield integrated into a single unit. Figure 3 shows the IB module as consisting of a front part which is made up of three electrically insulated boxes, attached to a single rear part. Breeding and shielding material fills the front part, while the rear part consists of water cooled steel. As in the case of the OB blanket, the same coolant loop is used for the blanket and shield, while the first wall is separately cooled.

FABRICATION AND ASSEMBLY

Fabrication of both OB and IB blanket modules is based on the ability to make cooling panels with built-in channels and then forming them into the needed shapes. Although the particular shape of panels used in the design of the blanket is not available from the shelf, the processes used in fabricating many shapes of cooling panels can be used to produce them.

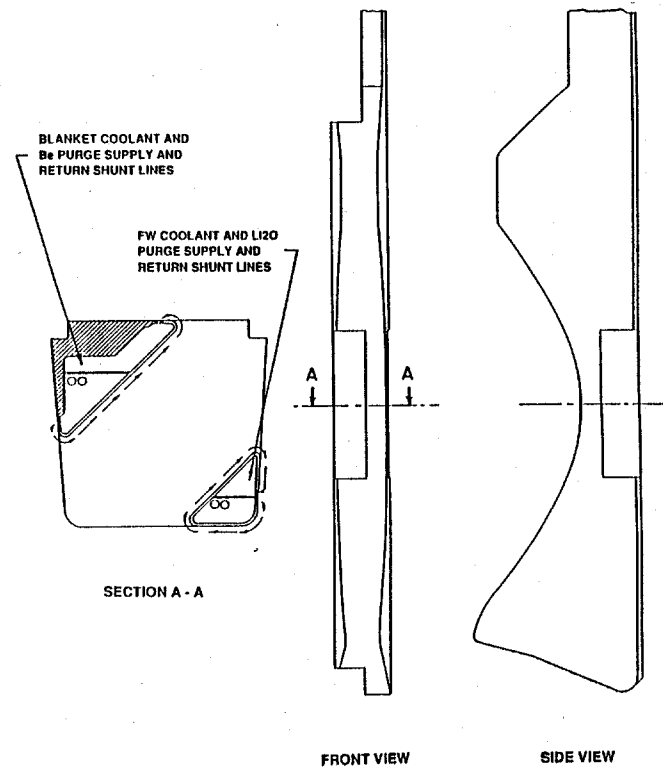

Figure 7. Side module with NB penetration.

The Dean Products Inc. company of Brooklyn, NY produces a product called Panelcoil. These Panelcoils are fabricated from two sheets of metal, usually stainless steel, where either one, or both sheets are embossed with a pattern and then seam welded (continuously spot welded) together. The pattern then forms coolant channels in different configurations. These panels are then formed into various shapes such as cones, spheres, cylinders and rectangular boxes. The panels can be bent both parallel and perpendicular to the direction of the channels.

In the present design, the FW and the blanket panels are made of plates with flat sides which have coolant channels built in. Sheets of stainless steel are hot rolled or extruded with the imprint of one half of the coolant channels on one side. The sheets are then assembled to form the complete channels and continuously spot welded across the channel separations. The panels are then bent into the proper shapes needed to form a module. A module can be made out of several segments and then E-beam welded together into a complete unit as long as the weld does not cut across any coolant channels. At a meeting with technical representatives from Dean Products Inc., we were assured that such procedures were entirely possible, although for them to produce such panels today, would require special tooling of their production line and the sheets would have to be extruded at the steel mill.

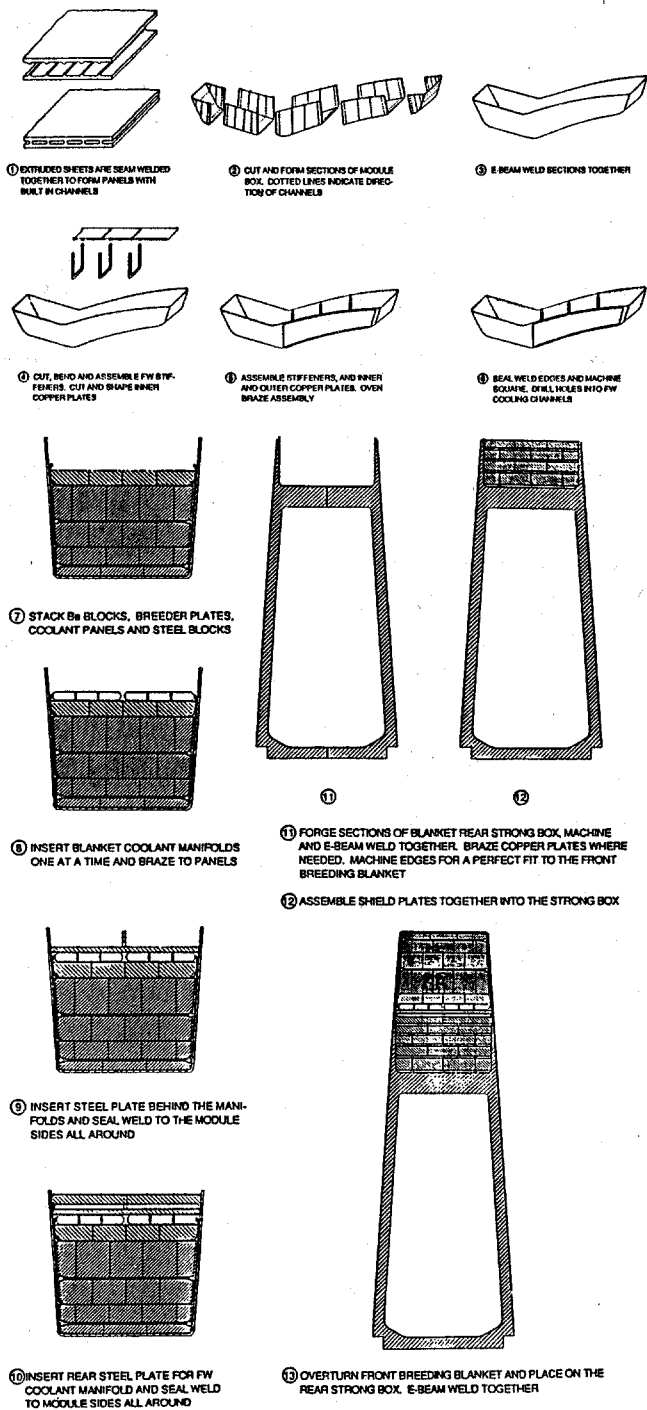

Figure 8. Sequence of operations needed to fabricate an OB central module.

The OB blanket module boxes present the biggest fabrication challenge, because of their unusual shape and the required toroidal cooling. As presently envisaged, the panels can be shaped by drawing and bending operations, but great care must be exercised to insure that the channels

remain properly directed. As mentioned earlier, the front boxes will most likely be made out of several sections which are subsequently E-beam welded together. Figure 8 shows a sequence of operations resulting in a completed OB side module.

The IB module is also made of the same kind of panels. Because of the need for segmenting the module into three electrically insulated parts and because the coolant channels are running poloidally, it was decided to make the individual boxes out of E-beam welded segments as shown in Figure 3. Each of the three front segments is fabricated separately, then assembled together with ceramic insulation in between and E-beam welded in the rear. The assembly is then bolted to the rear strongbox which comprises part of the shield and coolant manifolds.

SUMMARY

The mechanical design and fabrication of the U.S. solid breeder blanket for ITER is presented. The blanket utilizes thin LiO_2 solid breeder zones interleaved with Be zones and water cooling panels in a slab configuration. A scheme for supporting the first wall against disruptions is presented. Blanket modifications for accommodating various penetrations are also given. A sequence of fabrication steps are outlined for building an outboard central upper module. For details of other aspects of the U.S. solid breeder design, the reader is directed to many companion papers, in these proceedings.

ACKNOWLEDGEMENT

Early contributions by Brad Nelson and more recently by Paul Goranson and D. Williamson, all three of the Fusion Engineering Design Center, Oak Ridge National Laboratory, are acknowledged. Support for this research has been provided by the Fusion Energy Division of the U.S. DOE.