

THREE-DIMENSIONAL NEUTRONICS ANALYSIS FOR THE LIBRA-SP LIGHT ION FUSION POWER REACTOR

M.E. Sawan

Fusion Technology Institute
University of Wisconsin-Madison

*Presented at the 13th Topical Meeting on the Technology of Fusion Energy,
June 7-11, 1998, Nashville TN*

LIBRA-SP

1000 MW_e

Self-pinch propagation from diode

7.8 MJ of 30 MeV Li ions

Target yield of 552 MJ

Repetition rate of 4.2 Hz

PERIT units for wall protection

Tiny nozzles spray fans of Li₁₇Pb₈₃

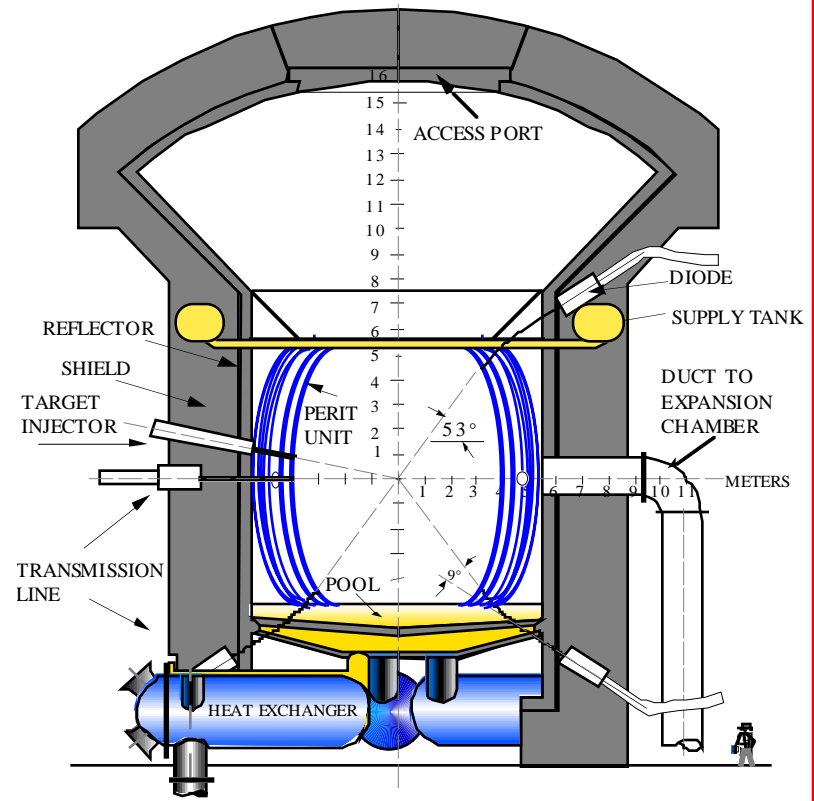

Background

- Neutronics analysis performed previously for LIBRA-SP chamber using 1-D spherical geometry for regions surrounding target
- 1-D local nuclear parameters combined with coverage fractions to determine overall TBR and energy multiplication
- This approach yields reasonable estimates in preliminary stages of design
- larger differences expected for local damage and heating due to
 - Impact of different materials in chamber regions on secondary n and γ
 - Different angular distribution of incident neutrons
- 3-D neutronics analysis performed for LIBRA-SP chamber and results compared to 1-D results

3-D Computational Model

1.2 m thick PERIT region
0.5 packing fraction
8% HT-9, 92% LiPb in tubes
90% ^6Li enrichment

0.6 m deep LiPb pool
0.25 m thick perforated splash plate
80% HT-9, 20% LiPb
0.5 m deep sump tank of LiPb

0.5 m thick chamber wall
90% HT-9, 10% LiPb

Chamber surrounded by concrete
biological shield

- Monte Carlo code MCNP-4A
- International fusion data library FENDL-1

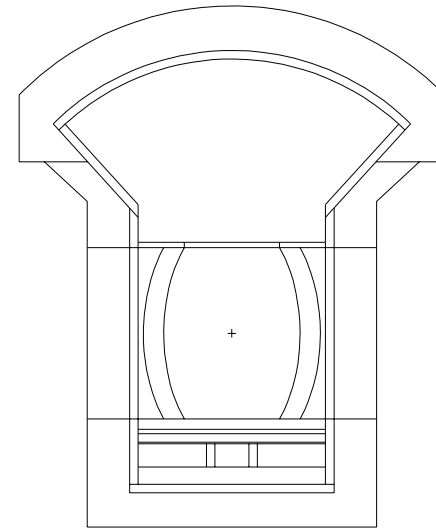

Target Neutronics

- Detailed results of hydrodynamics calculations utilized to perform target neutronics calculations that take into account
 - Varying configuration during burn
 - Distributed material densities
 - Distributed fusion neutron source profile

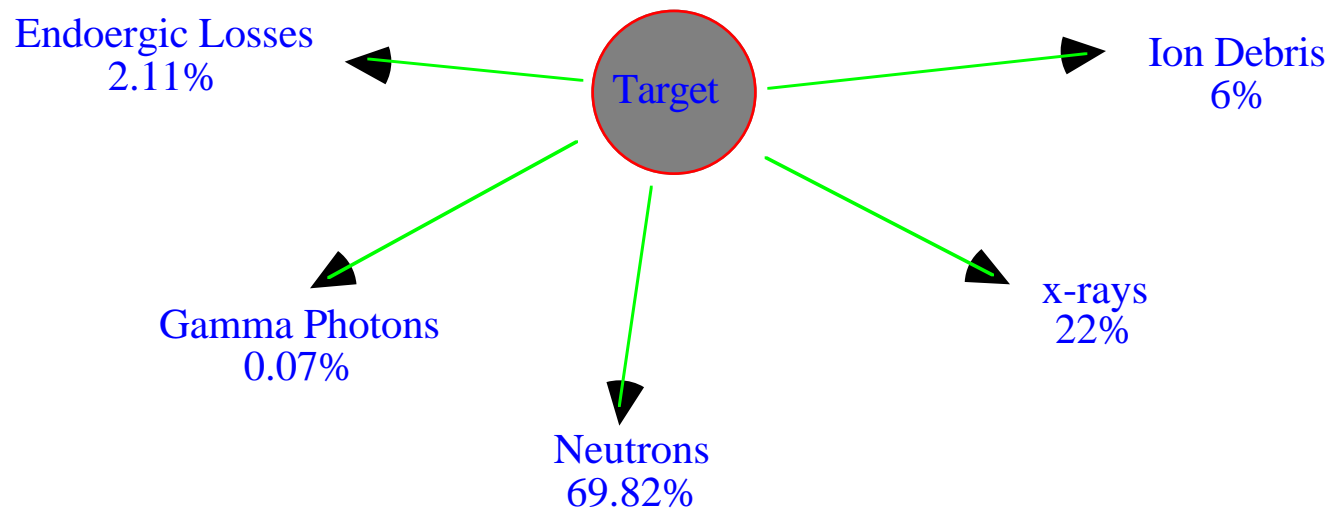

Source Sampling

Target spectrum used for sampling energy of source in 3-D calculation

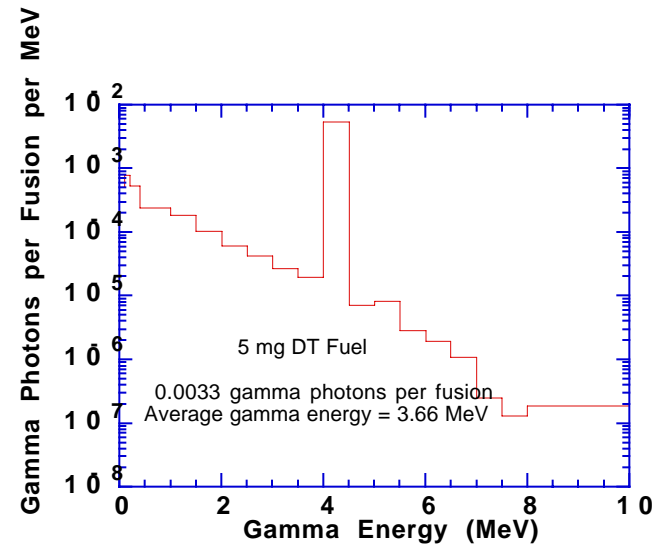
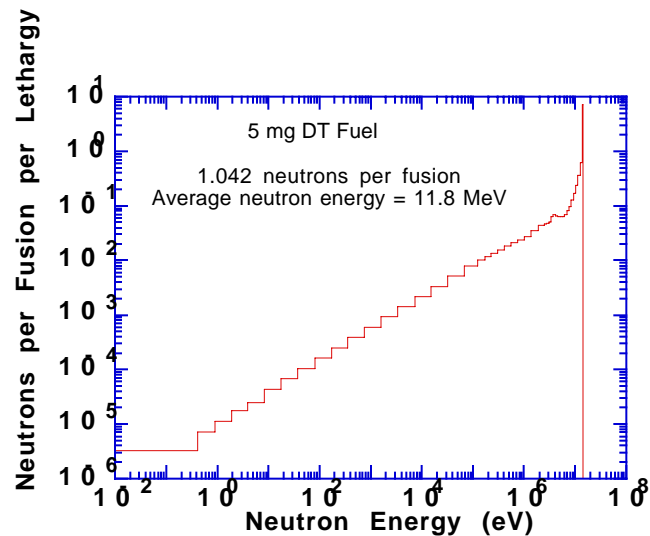

Two separate calculations performed and nuclear response results added

1. Coupled neutron-gamma calculation with target neutron source spectrum
2. Gamma transport calculation with target gamma source spectrum

Tritium Breeding

- The overall TBR from 3-D calculation is 1.4
- This is only 3% lower than the 1.44 value predicted from coupling the 1-D results with coverage fractions

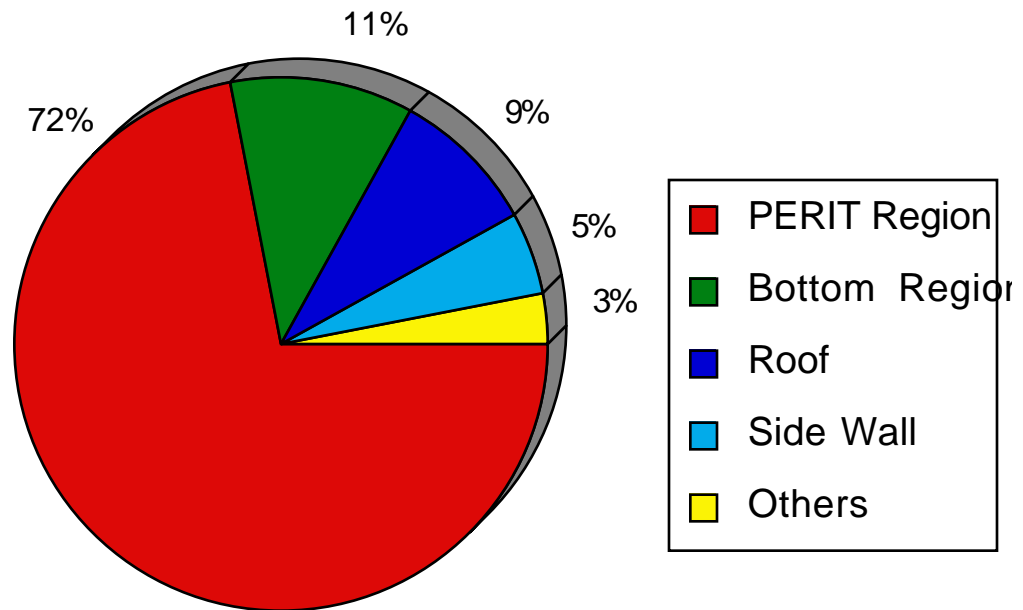

Energy Multiplication

- Nuclear energy multiplication, M_n , is 1.255
- This is only 2% lower than the 1.288 value from 1-D calculations
- Overall reactor energy multiplication, M_o , defined as ratio of total power deposited (n, g, x, debris) to DT fusion power, is 1.157
- Total thermal power is 2681 MW
 - 2032 MW deposited by neutrons and gamma
 - 649 MW deposited at front surfaces by x-rays and ion debris

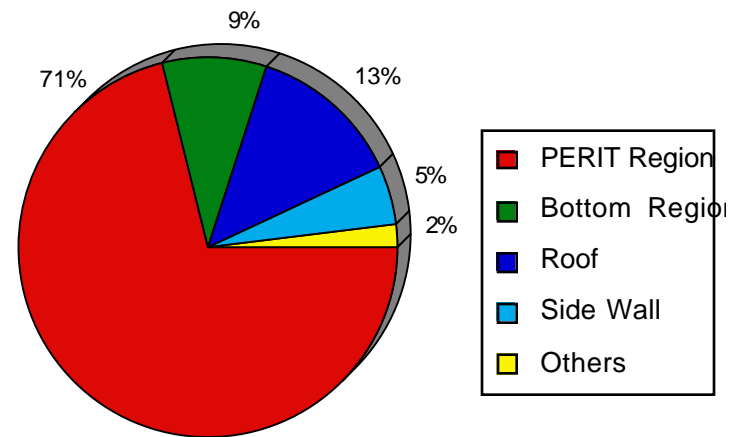

Nuclear Heating in LIBRA-SP

Peak Radiation Damage in PERIT Tubes

- Front surface at 4 m
- Neutron wall loading = 7.4 MW/m^2
- dpa limit of 150 dpa used for HT-9
- Peak dpa rate is $67.1 \text{ dpa/FPY} \Rightarrow 2.2 \text{ FPY lifetime}$
- $\text{He/dpa} = 6.6$

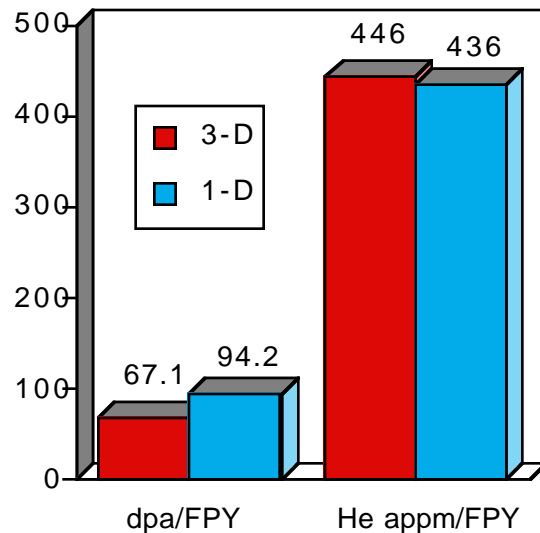

- dpa from 3-D is 30% lower than from 1-D
- Less secondary neutrons due to
 - mushroom shaped configuration
 - lower neutron multiplication in steel roof
- He production is slightly larger (2%) than 1-D estimate because of harder spectrum of secondary neutrons scattered from roof

Peak Radiation Damage in Side Wall

- Side wall at 5.2 m
- Peak dpa rate is 2.4 dpa/FPY
- For 30 FPY of operation, end-of-life peak dpa in side chamber wall is 73 dpa
- It easily qualifies as a lifetime component with a comfortable margin of 2
- He/dpa = 0.4

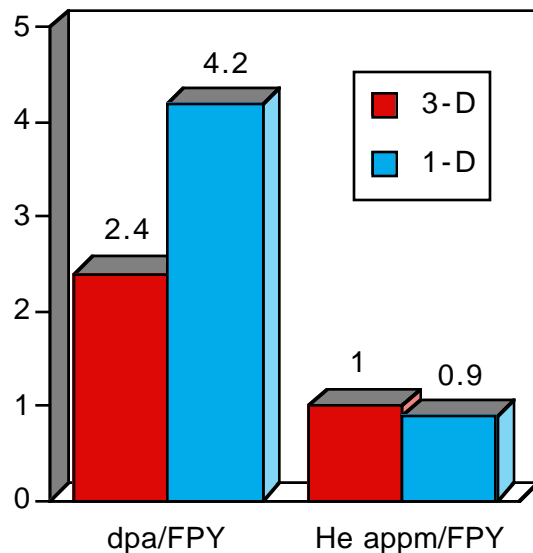

- dpa from 3-D is 42% lower than from 1-D
- Less secondary neutrons due to
 - mushroom shaped configuration
 - lower neutron multiplication in steel roof
- He production is slightly larger (7%) than 1-D estimate because of harder spectrum of secondary neutrons scattered from roof

Peak Radiation Damage in Bottom Perforated Plate

- Bottom perforated plate at 5.6 m
- Peak dpa rate is 1.1 dpa/FPY
- For 30 FPY of operation, end-of-life peak dpa in side chamber wall is 33 dpa
- It easily qualifies as a lifetime component with a comfortable margin of 5
- He/dpa = 0.48

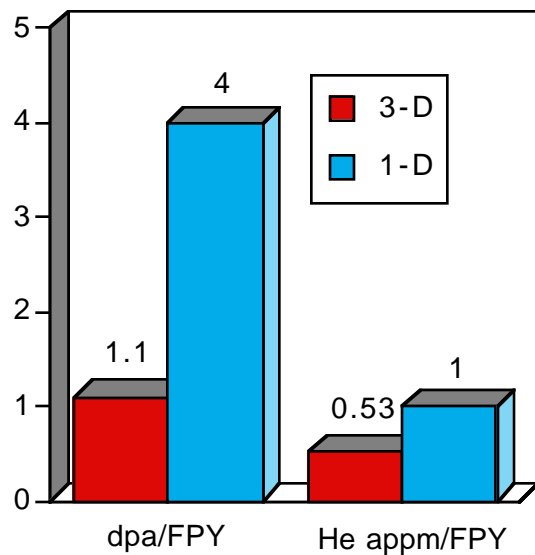

- dpa from 3-D is a factor of 4 lower than 1-D
- He production is a factor of 2 lower than 1-D
- Less secondary neutrons due to
 - mushroom shaped configuration
 - lower neutron multiplication in steel roof and PERIT tubes
- Effect less pronounced for He production because of harder spectrum of secondary neutrons

Peak Radiation Damage in Roof

- Top roof wall at 17 m
- Neutron wall loading = 0.4 MW/m^2
- Peak dpa rate is 3.45 dpa/FPY
- For 30 FPY of operation, end-of-life peak dpa in side chamber wall is 103 dpa

- Side wall of roof completely shadowed from direct source neutrons

- Only secondary neutrons scattered back from top dome of roof contribute to damage in side of roof

- Peak dpa in side of roof is 33% lower than in top dome of roof and He production is lower by a factor of 15

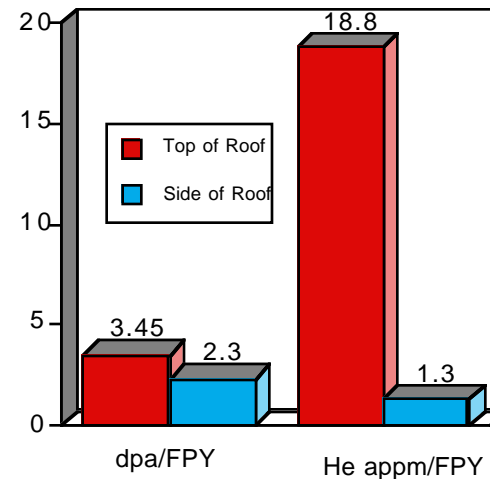

Conclusions

- The overall tritium breeding ratio is 1.4 and the overall energy multiplication is 1.16
- Calculated damage rates in the chamber wall, roof, and bottom perforated plate imply that these components will last for the whole plant lifetime
- The PERIT tubes will require several replacements with the front row having a lifetime of 2.2 FPY
- Combining 1-D results with coverage fractions to determine overall TBR and M leads to values within only 3% of those from detailed 3-D calculations
- Larger differences up to a factor of 4 observed in local parameters due to geometrical configuration and impact of different materials used in chamber regions on secondary neutrons and gamma photons